

# Miniature Automotive PCB Relay

# G8QN

- SPDT Contact Form (1C)
- Fully Sealed Construction
- Fully Automated Assembly
- Suitable for reverse motor applications (2 relays)
- High Performance PCB Relay
- Made in USA



## Available Types

Type	Description
G8QN-1C4-12V	Standard
G8QN-1C4-9V	High Sensitivity (Low Pull-in Voltage)
G8QN-1C4-05-12V	High Temperature (105°C)
G8QN-1C4-01-12V	High Contact Gap (0.7mm min.)

\*Certain relay types may be combined (Contact Omron for availability.)

## Contact Data

Max. Switching Current	30A
Max. Switching Voltage	16V
Max. Carry Current	30A (at 20°C for 1 hour)
Min. Carry Current	100mA
Contact Material	Silver-tin oxide

## Coil Ratings (at 20°C)

Type	Rated Voltage	Coil Resistance (±10%)	Nominal Power Consumption	Pull in Voltage	Dropout Voltage
G8QN-1C4-12V	12VDC	210Ω	685mW	< 6.6V	>0.6V
G8QN-1C4-9V	9VDC	180Ω	450mW	<5.7V	>0.6V
G8QN-1C4-05-12V	12VDC	210Ω	685mW	< 6.6V	>0.6V
G8QN-1C4-01-12V	12VDC	115Ω	1252mW	< 6.4V	>0.6V

## Typical Applications

Power Windows / Power Door Lock
Smart Junction Box and Module Applications
Seat Adjustment
Sunroof
Horn
Fog lamp
Heated exterior side mirrors
Wiper motor
Washer pump

## Characteristics

Max. Initial Contact Voltage Drop / Resistance		50mV / 50mΩ (@ 1A, 12VDC) 100mV / 100mΩ (@ 1A, 12VDC) (high gap type)
Operate Time		10ms max. (3.5ms typical) @ 12VDC
Release Time		5ms max. (1.5ms typical)*
Bounce Time	Operate	5ms max. (0.5ms typical)
	Release	5ms max. (1.0ms typical)
Switching Frequency	Mechanical	18,000 operations per hour
Insulation Resistance		100MΩ min. at 500VDC
Dielectric Strength		1.0mA max leakage at 440Vac/60Hz for 1 minute between coil & contacts and between N.O. & N.C. contacts.
Vibration	Mechanical durability	10-500Hz, 5G, 1.5mm total amplitude
	Malfunction durability	10-500Hz, 5G, 1.5mm total amplitude
Shock	Mechanical durability	100G half sine 6ms duration (980m/s <sup>2</sup> )
	Malfunction durability	100G half sine 6ms duration (980m/s <sup>2</sup> )
Operating Ambient Temperature Range		-40 to 85 °C (105°C for high temp type)
Humidity		35 to 85% RH
Service Life	Mechanical	1,000,000 operations min.
	Electrical	100,000 operations min. (load dependant)
Mass		5.9g (approx.)

\* External coil suppression will cause a measurable increase in release times and may cause the relay's characteristic to fall out of the specifications given here.

## Characteristics Reference Data

<b>Durability Test Data</b>			
Relay	Load Type	Current	Cycles Tested
<b>G8QN &amp; G8QW</b>	Door lock motor	18 - 20 A Inrush	200,000
	Power window motor (locked)	34 A	200,000
	Power window motor (locked)	23 A	200,000
	Sun roof motor (free)	27 A Inrush 3 A Steady state -19 A breaking current	100,000
	Horn load	14 A	200,000

## Characteristics Reference Data (continued)

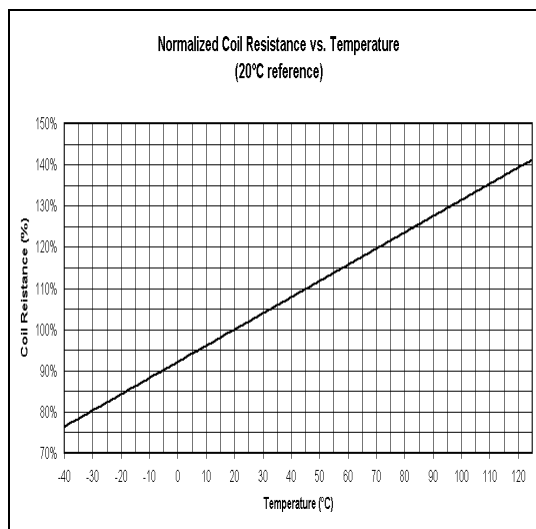
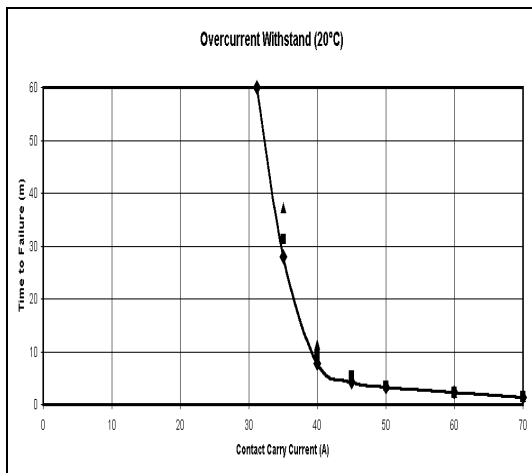

Example: Resistance of 210Ω coil  
 = 75% of 210Ω at -40°C, or 158Ω  
 = 100% of 210Ω at 20°C, or 210Ω  
 = 125% of 210Ω at 85°C, or 263Ω

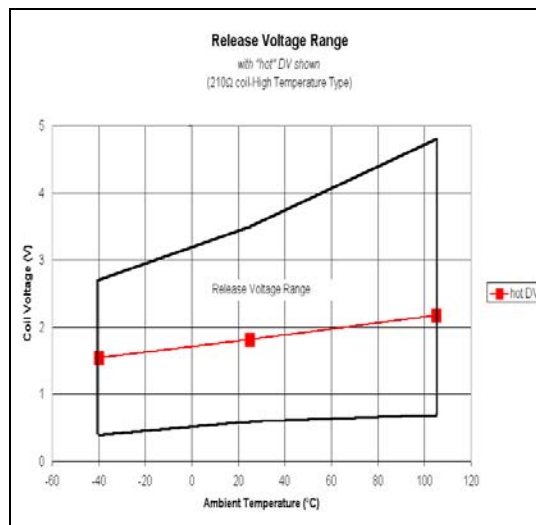
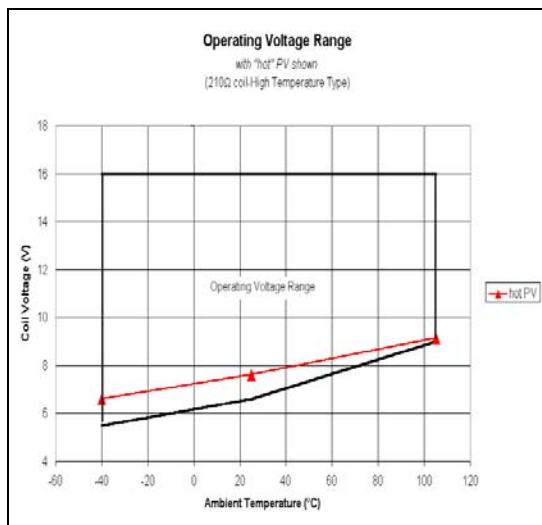

## Dimensions

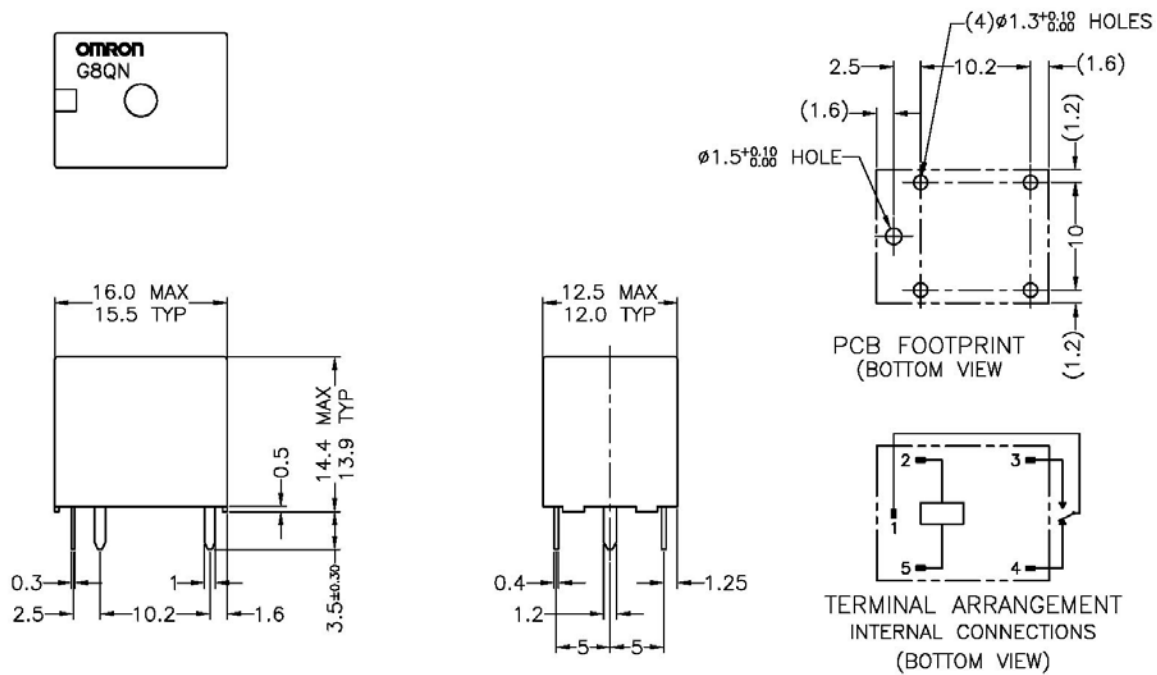

## Tube Packaging

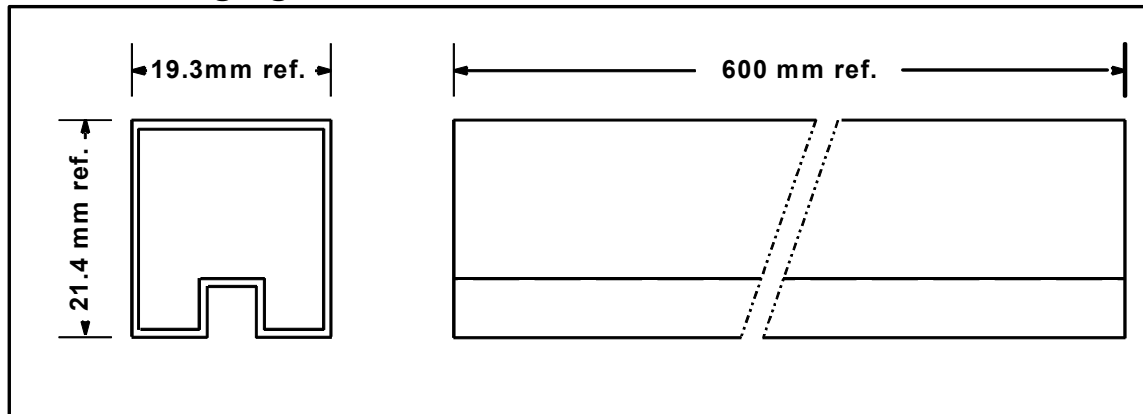

47 relays per tube, 36 tubes per box (1692 relays per box)

### Notes:

1. For additional information, please contact Omron.
2. Prior to receipt of order, specifications subject to change without notice.
3. This specification sheet is intended to be a guideline for application of this product. The information contained is believed to be correct. However, it is impossible for Omron to evaluate every possible use. It is the user's responsibility to determine product suitability in any application.
4. Omron can meet some special performance characteristics upon request.
5. All data at 20°C unless otherwise noted.
6. If several relays are to be mounted on a single PCB, they must be given at least 3mm clearance on all sides.